

## EXAMINATION INSTRUCTIONS

### General Instructions for Students Using PAPER BLUEBOOKS:

- You have 2 hours to complete this exam.
- Write both your Exam Number **and your Section Leader's name** on each one of your Bluebooks.
- Do NOT put your name on this Exam or on your Bluebooks.
- This is a closed book exam. You may not use any materials other than those provided.
- You may not use a computer or electronic communication device during the exam.
- **Write in ink in the Bluebook.**
- Write on only one side of the page in the Bluebook.
- Write neatly in the Bluebooks. No credit will be given for any word about which there is any question.

CHECK NOW TO VERIFY THAT YOU HAVE A TOTAL OF 7 PAGES  
INCLUDING THIS PAGE.

### General Instructions for Students Using ELECTRONIC BLUEBOOK SOFTWARE:

- You have 2 hours to complete this exam.
- Include both your Exam Number **and your Section Leader's name** in your answer in the Electronic Bluebook.
- Do NOT put your name on the Exam or in your answer in the Electronic Bluebook.
- This is a closed book exam. You may not use any materials other than those provided.
- You may only use a computer to run the Electronic Bluebook program. You may not access anything on the computer other than the Electronic Bluebook program.
- Internet access is NOT permitted during the exam.
- You may not use an electronic communication device during the exam.

CHECK NOW TO VERIFY THAT YOU HAVE A TOTAL OF 7 PAGES  
INCLUDING THIS PAGE.

Claim Writing Instructions:

- Read the “Invention Disclosure for a Pumpkin Illumination Device” carefully.
- Write a total of seven apparatus claims. The seven apparatus claims should include one independent claim and the following six dependent claims:
  - a) One dependent claim defining a battery chamber.
  - b) One dependent claim specifying a number of batteries in the battery chamber.
  - c) One dependent claim specifying a size of the angle between each tab and the circular ring.
  - d) One dependent claim specifying a material from which the flexible foot is made.
  - e) One dependent claim that further defines one of the elements in the independent claim and is different from any of the previous claims.
  - f) One dependent claim that adds an additional element to the combination claimed in the independent claim and is different from any of the previous claims.
- Number the claims as though they are being filed in a patent application rather than identifying the claims with the letters and/or descriptions used in the above instructions.
- Write the dependent claims in the order listed in the above instructions. Make sure each dependent claim depends from an appropriate claim for what is being recited.
- The independent claim must particularly point out and distinctly claim the invention over the prior art provided in the invention disclosure.
- All claims must be completely supported by the invention disclosure.
- Carefully check the mechanics of all of your claims.
- All draft versions of claims should be written on scratch paper. Write only the final version of your claims in the Bluebooks.
- Only the seven claims just described will be graded. Any additional writing provided, including extra claims or explanations of any claims, will NOT be considered and should NOT be written in the Bluebooks.

### Description of the Prior Art

With millions upon millions of pumpkins being sold each year to homeowners and trick-or-treaters throughout the world, jack-o-lanterns are perhaps the best-known symbol of Halloween. Classic jack-o-lanterns are lanterns made of a pumpkin or other vegetable, having been prepared so as to show, for example, features of a human face in illumination. The tradition of hollowing-out and carving a pumpkin to form a jack-o-lantern, and lighting it from within, is one that harkens back hundreds of years to Irish folklore and to the story of a disreputable and immoral blacksmith named Jack, whose notorious propensity for the drink was surpassed only by his penchant for playing mean-spirited practical jokes. Legend has it that Jack even played a trick or two on the devil himself, such that, on dying, Jack was allowed entrance to neither heaven nor hell. The story goes that Jack was instead doomed to wander for eternity in the grey darkness of limbo, with only a burning ember to light his way; the ember was placed inside a hollowed-out turnip to maintain its light on his unending journey. The first fearful believers in Jack's eternal plight carved similar lanterns out of turnips and beets, and placed lit candles inside to ward off evil spirits. Over the years, the tradition has evolved and, while jack-o-lanterns are most commonly carved from pumpkins today, they remain one of the spookiest and most chilling images to greet a young trick-or-treater travelling door to door on Halloween. Of course, with the advent of the jack-o-lantern as a prominent symbol of Halloween, there has been an increasing demand to safely provide for the proper illumination thereof.

Typically, in order to form a jack-o-lantern from a pumpkin, a person will use a pointed knife to carve a continuous circle through an outer surface of a top portion of the pumpkin, creating a removable lid from the top portion and defining a corresponding aperture in the top portion of the pumpkin. The lid is then removed and a mass of pumpkin pulp and seeds contained inside is withdrawn, either by hand or using a spoon or other utensil, through the corresponding aperture in the top portion of the pumpkin. Having so hollowed out the pumpkin, the pointed knife is then utilized to carve a face or other image into the outer surface of the pumpkin. A light source may then be positioned within the jack-o-lantern for illumination.

Historically, a lit candle positioned on an inside bottom surface of the jack-o-lantern has been the most common way of illuminating the jack-o-lantern, but use of the candle in this manner has inherent problems. For one, every pumpkin has a raised mound located on its inside bottom surface, also known as a bloom point, making it very hard to securely balance a candle in position thereon. This difficulty in securely balancing the candle on the bloom point leads to a significant possibility that the candle may become overturned, posing a serious risk of fire in the event that the candle is, or was, lit.

Prior art patent No. 6,106,279 (Hedlund) attempts to solve this problem with a candle holder for a Jack-O-Lantern. FIGS. 1 and 2 from the Hedlund patent are shown on the next page. Any reference numbers shown on the next page that are not mentioned in this description of Hedlund are not important for this exercise. The Hedlund patent discloses a candle holder 10 having a hemispherical shape similar to the shape of a top portion of a pumpkin. The Hedlund candle holder holds a candle 14 and defines a hollow interior portion 28 which accommodates the bloom point of a pumpkin when one or more anchors 30 of the candle holder are embedded straight into the inside bottom surface of the jack-o-lantern.

However, another drawback of illuminating a carved pumpkin with a candle is that, as the candle burns over a period of time, it diminishes in size thereby affecting overall illumination of the carved pumpkin. Additionally, where the pumpkin is located outdoors, there remains the possibility that a gust of wind will merely extinguish the lit candle. There is therefore, a need in the industry to provide an alternative means for illuminating the interior of a carved pumpkin.

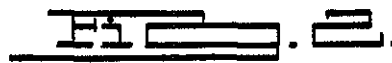
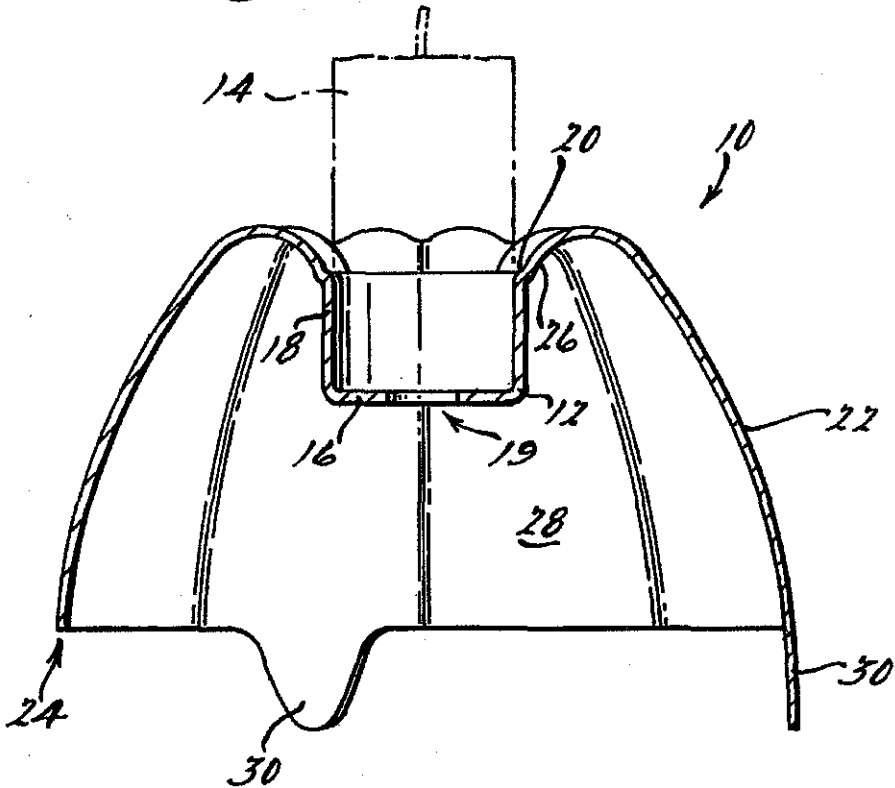
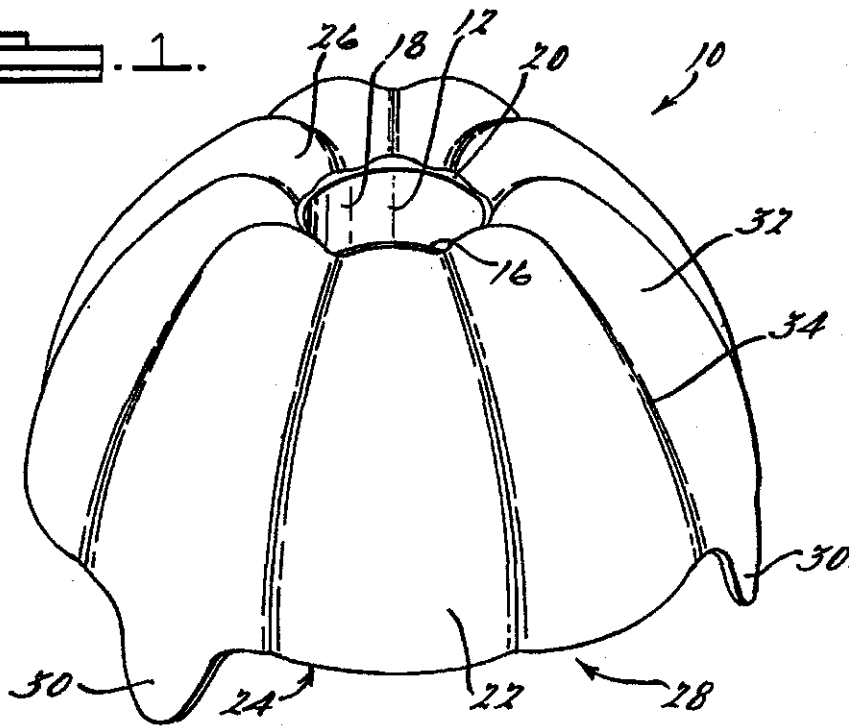
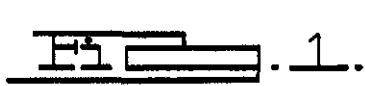

### Invention Disclosure for a Pumpkin Illumination Device

A new pumpkin illumination device embodying the principles and concepts of the present invention and generally designated by the reference numeral 10 is now described by reference to the following Figures 1, 2, 3 and 4. The pumpkin illumination device 10 is mounted in a pumpkin 12 having a hollow interior and cut outs in the shape of a face as shown in FIG. 1.

FIGS. 2 and 3 are more detailed views of the pumpkin illumination device 10 shown in FIG. 1. The pumpkin illumination device 10 consists of a base member 14 having a generally cylindrical configuration. The base member 14 has an externally threaded open upper end 16, a closed lower end 18 and a cylindrical side wall therebetween.

The base member 14 has an interior battery chamber (not shown). The battery chamber is an opening of an appropriate size to receive and hold a battery 22. The opening is defined by the externally threaded open upper end 16, the closed lower end 18 and the cylindrical side wall. A spring 20 is disposed within the battery chamber. In a preferred embodiment, the pumpkin illumination device 10 operates with one battery; however, two batteries may be utilized in which case the battery chamber in the interior of the base member 14 is adapted to house two batteries.

The open upper end 16 has an end cap 24 removably coupled thereto. The end cap 24 is shown in FIG. 4. The end cap 24 has an aperture 26 through a central portion thereof for receiving a lower end of a light bulb 28 there through whereby the lower end of the light bulb 28 is in operative communication with the battery 22.

The pumpkin illumination device 10 also consists of a support bracket 30. The support bracket 30 couples with the base member 14. The support bracket 30 includes an upper circular ring 32 with an aperture for receiving the base member 14 therein. The base member 14 slides within the aperture of the circular ring 32 of the support bracket 30. The support bracket 30 elevates the base member 14 so as to provide sufficient space under the base member 14 for the bloom point of the pumpkin.

The circular ring 32 has a pair of tabs 34 extending downwardly in an angular orientation there from. Preferably, the interior angle (shown in FIG. 3 as  $\theta$ ) between each tab 34 and the circular ring 32 is not less than 90 degrees and not more than 135 degrees. While the circular ring 32 must have a minimum of two tabs 34 as shown in FIGS. 2 and 3, it is preferable for the circular ring 32 to have more than two tabs 34. Each of the tabs 34 has a flexible foot 36 disposed on a free end. The support bracket 30 may be positioned within the pumpkin 12 so that each flexible foot 36 rests on the bottom of the pumpkin. Alternatively, each flexible foot 36 may be more securely positioned within the pumpkin 12 by bending each flexible foot 36 and pressing so that the flexible foot 36 penetrates the bottom of pumpkin 12. Accordingly, each flexible foot 36 is made of a thin bendable metal material such as aluminum, tin, brass, or copper.

In use, the present invention is an alternative means to illuminate a Halloween jack-o-lantern. The present invention would be positioned within the interior of the jack-o-lantern after it had been carved and the pulp and seeds were removed. The present invention provides individuals with added safety by reducing the incidence of fires that originate from candles burning within jack-o-lanterns. Moreover, the pumpkin illumination device 10 can also be used to illuminate enclosures other than real, hollowed-out pumpkins, including, but not limited to, artificial pumpkins made from PVC plastic.

FIG. 1

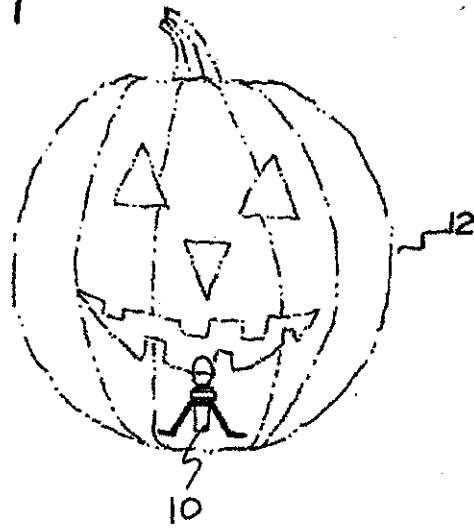

FIG. 2

